

Потолочные вентиляторные модули ELDON RFU

Технические характеристики



Архангельск (8182)63-90-72
Астана (7172)727-132
Астрахань (8512)99-46-04
Барнаул (3852)73-04-60
Белгород (4722)40-23-64
Брянск (4832)59-03-52
Владивосток (423)249-28-31
Волгоград (844)278-03-48
Вологда (8172)26-41-59
Воронеж (473)204-51-73
Екатеринбург (343)384-55-89
Иваново (4932)77-34-06

Ижевск (3412)26-03-58
Иркутск (395)279-98-46
Казань (843)206-01-48
Калининград (4012)72-03-81
Калуга (4842)92-23-67
Кемерово (3842)65-04-62
Киров (8332)68-02-04
Краснодар (861)203-40-90
Красноярск (391)204-63-61
Курск (4712)77-13-04
Липецк (4742)52-20-81

Киргизия (996)312-96-26-47

Магнитогорск (3519)55-03-13
Москва (495)268-04-70
Мурманск (8152)59-64-93
Набережные Челны (8552)20-53-41
Нижний Новгород (831)429-08-12
Новокузнецк (3843)20-46-81
Новосибирск (383)227-86-73
Омск (3812)21-46-40
Орел (4862)44-53-42
Оренбург (3532)37-68-04
Пенза (8412)22-31-16

Россия (495)268-04-70

Пермь (342)205-81-47
Ростов-на-Дону (863)308-18-15
Рязань (4912)46-61-64
Самара (846)206-03-16
Санкт-Петербург (812)309-46-40
Саратов (845)249-38-78
Севастополь (8692)22-31-93
Симферополь (3652)67-13-56
Смоленск (4812)29-41-54
Сочи (862)225-72-31
Ставрополь (8652)20-65-13

Казахстан (772)734-952-31

Сургут (3462)77-98-35
Тверь (4822)63-31-35
Томск (3822)98-41-53
Тула (4872)74-02-29
Тюмень (3452)66-21-18
Ульяновск (8422)24-23-59
Уфа (347)229-48-12
Хабаровск (4212)92-98-04
Челябинск (351)202-03-61
Череповец (8202)49-02-64
Ярославль (4852)69-52-93

Адрес сайта: www.eldon.nt-rt.ru || эл. почта: efd@nt-rt.ru

Thermal Management Ventilation Range

Roof fan unit | RFU

**Description:**

Roof fan unit for mounting on the top of the enclosure providing forced ventilation. The unit is easily installed with a quick fastening system, and the required cutout is the same for the different air flow.

Material:

Painted mild steel, and injection-moulded thermoplastic (ABS-FR) self extinguishing, UL94V0.

Temperature range:

-15 °C to +55 °C.

Type of connection:

Terminal strip.

Finish:

RAL 7035.

Pack quantity:

One roof fan unit.

230 V, 50/60 Hz

Unimpeded airflow (m³/h)	RFU+EFA Air flow (m³/h)	Filter mat (EN779)	Filtration efficiency (%)	Service life L10 (40°C)(h)	Bearing type	Noise (dB)	Item no.
500	268	No filter mat	No filter mat	50.000	Ball	67	RFU5003R5
700	427	No filter mat	No filter mat	40.000	Ball	69	RFU7003R5
1000	582	No filter mat	No filter mat	40.000	Ball	77	RFU10003R5
350	242	G4	>90	50.000	Ball	67	RFU5005R5
550	370	G4	>90	40.000	Ball	69	RFU7005R5
750	500	G4	>90	40.000	Ball	77	RFU10005R5

230 V, 50/60 Hz

IP	Cut-out (mm)	Weight (kg)	Connection	Current (A)	Power (W)	Fuse (A)	Item no.
33	291 x 291	5.55	Terminal strip	4 x 0.20/0.20	4 x 28/29	6	RFU5003R5
33	291 x 291	6.15	Terminal strip	0.35/0.45	80/100	6	RFU7003R5
33	291 x 291	6.45	Terminal strip	0.53/0.72	120/160	6	RFU10003R5
54	291 x 291	5.55	Terminal strip	4 x 0.20/0.20	4 x 28/29	6	RFU5005R5
54	291 x 291	6.30	Terminal strip	0.35/0.45	80/100	6	RFU7005R5
54	291 x 291	4.78	Terminal strip	0.53/0.72	120/160	6	RFU10005R5

115 V AC, 50/60Hz

Unimpeded airflow (m³/h)	RFU+EFA Air flow (m³/h)	Filter mat (EN779)	Filtration efficiency (%)	Service life L10 (40°C)(h)	Bearing type	Noise (dB)	Item no.
500	268	No filter mat	No filter mat	50.000	Ball	67	RFU5013R5
700	427	No filter mat	No filter mat	40.000	Ball	69	RFU7013R5
1000	582	No filter mat	No filter mat	40.000	Ball	77	RFU10013R5
350	242	G4	>90	50.000	Ball	67	RFU5015R5
550	370	G4	>90	40.000	Ball	69	RFU7015R5
750	500	G4	>90	40.000	Ball	77	RFU10015R5

115 V AC, 50/60Hz

IP	Cut-out (mm)	Weight (kg)	Connection	Current (A)	Power (W)	Fuse (A)	Item no.
33	291 x 291	5.60	Terminal strip	4 x 0.30/0.30	4 x 29/24	6	RFU5013R5
33	291 x 291	4.56	Terminal strip	0.66/0.80	75/90	6	RFU7013R5
33	291 x 291	4.78	Terminal strip	0.96/1.40	110/160	6	RFU10013R5
54	291 x 291	5.33	Terminal strip	4 x 0.30/0.30	4 x 29/24	6	RFU5015R5
54	291 x 291	4.56	Terminal strip	0.66/0.80	75/90	6	RFU7015R5
54	291 x 291	4.78	Terminal strip	0.96/1.40	110/160	6	RFU10015R5

(1) The value in the table is for the combination RFU + EFA500-700R5.



Dimensional drawing | RFU

RFU5003R5 / RFU5005R5
RFU5013R5 / RFU5015R5

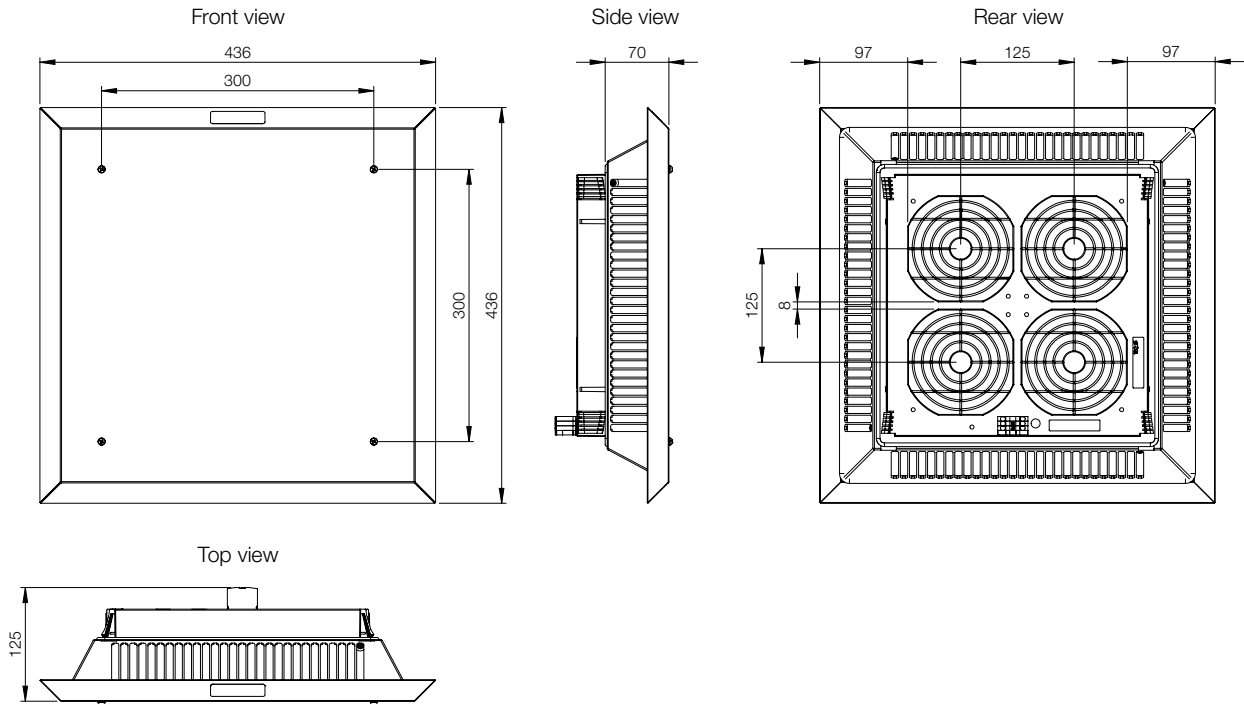

RFU5003R5 / RFU5013R5
Static pressure diagram

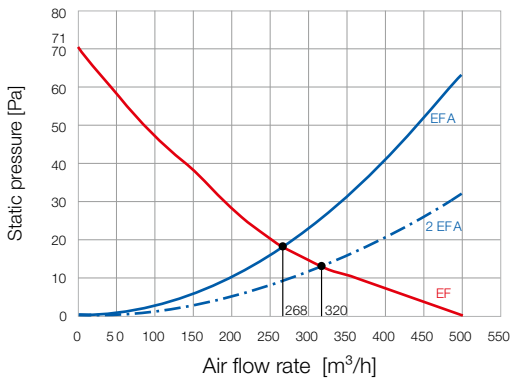

RFU5005R5 / RFU5015R5
Static pressure diagram

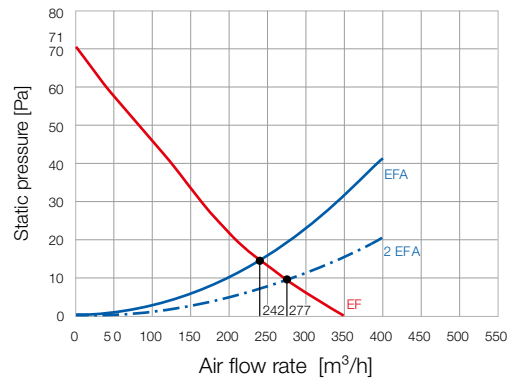

Performance

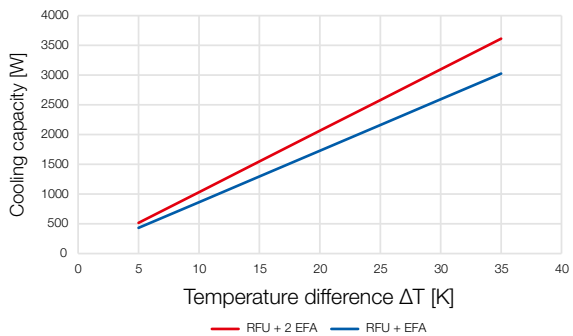

Performance

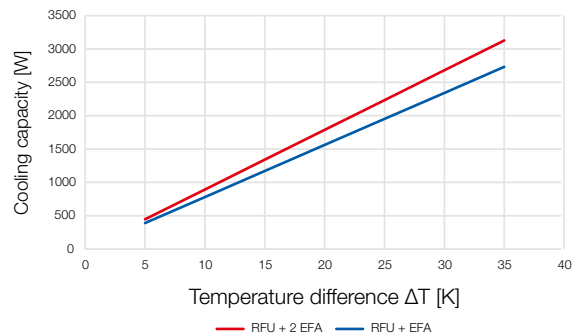

RFU7003R5 / RFU7005R5
RFU7013R5 / RFU7015R5

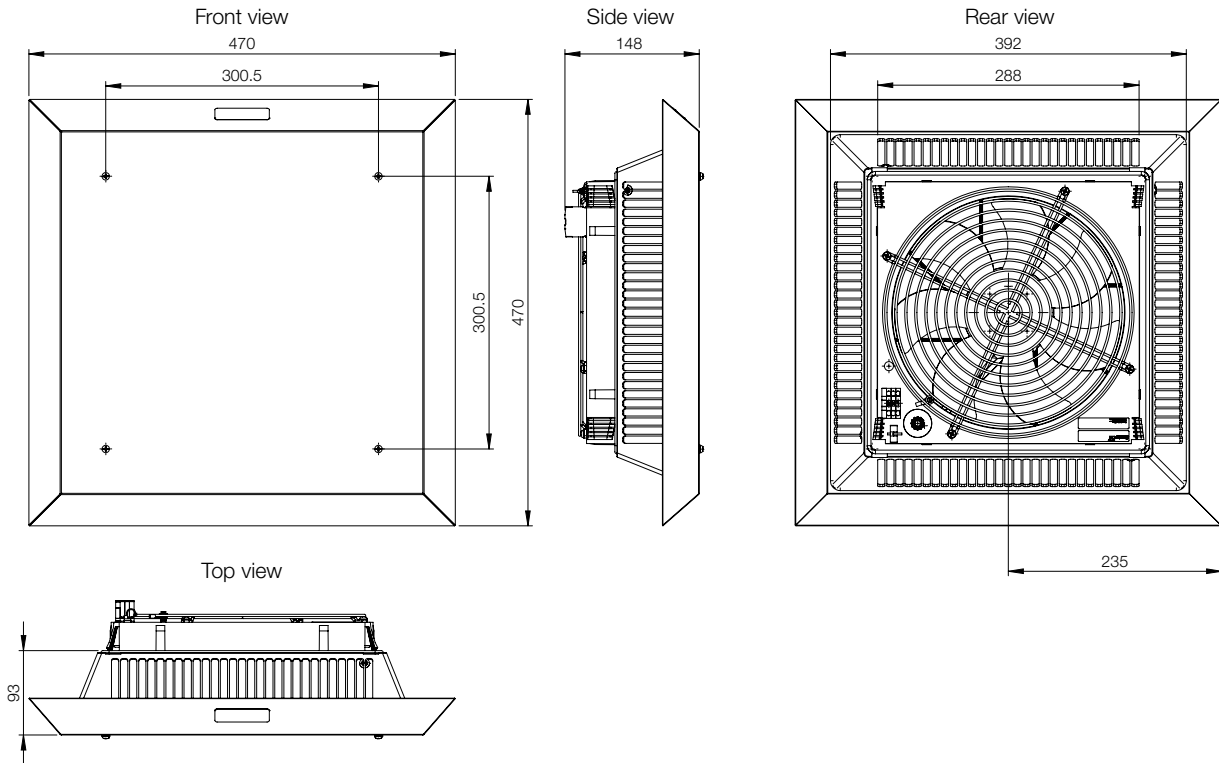

RFU7003R5 / RFU7013R5
Static pressure diagram

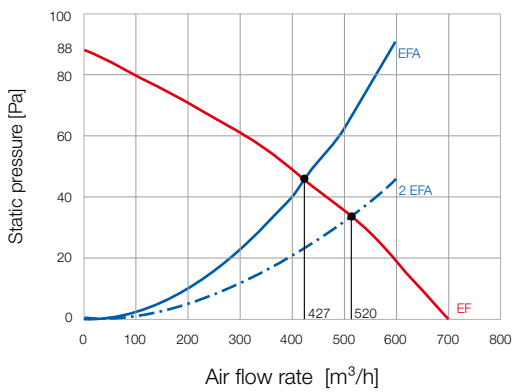

Performance

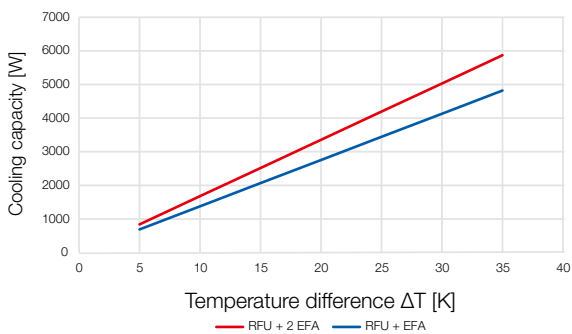

RFU7005R5 / RFU7015R5
Static pressure diagram

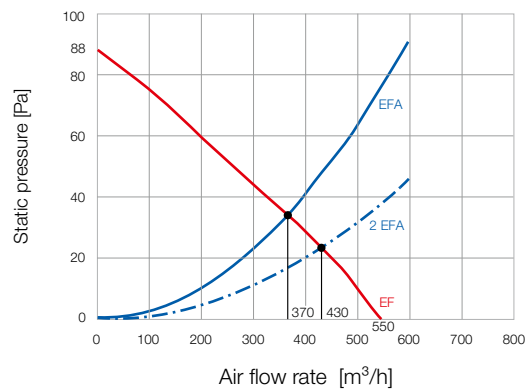

Performance

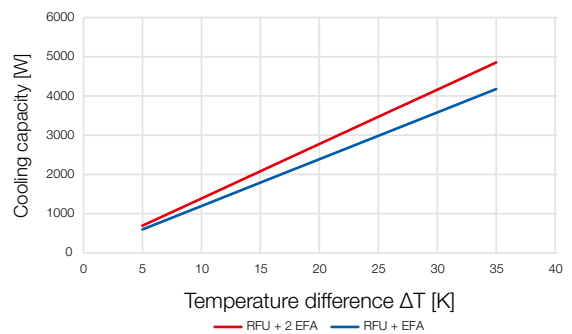

Dimensional drawing | RFU

RFU10003R5 / RFU10005R5
RFU10013R5 / RFU10015R5

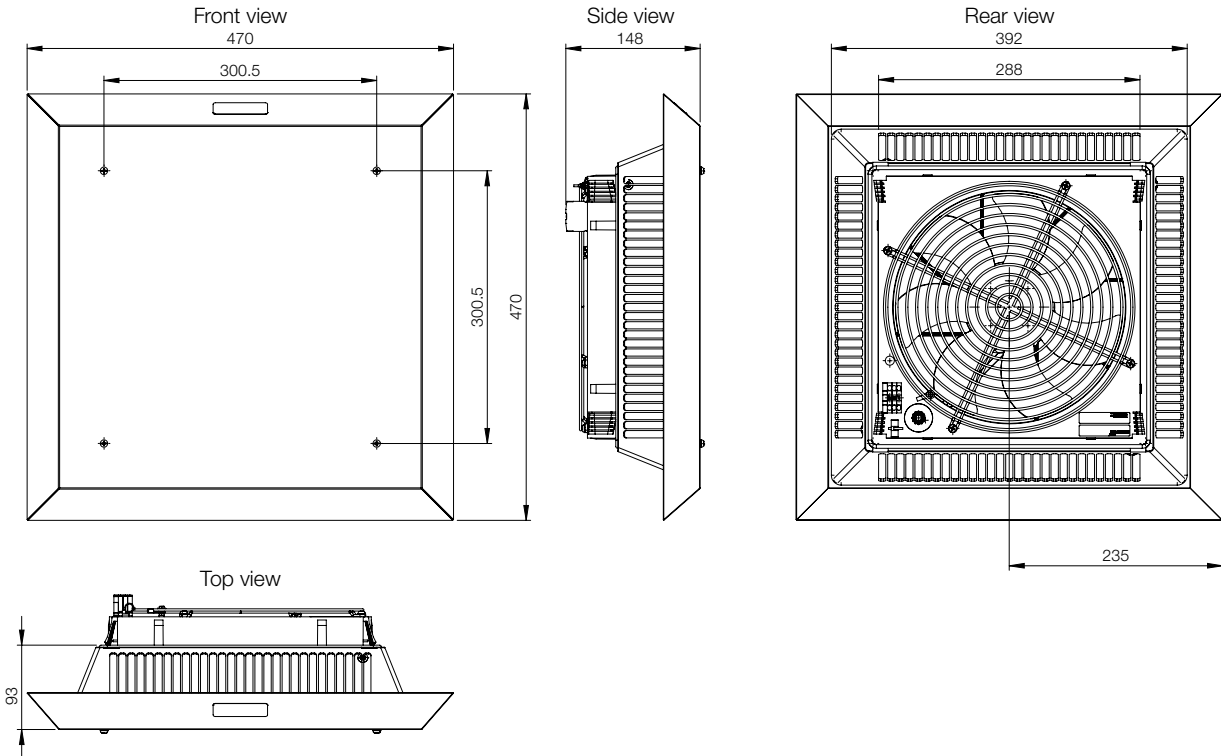

RFU10003R5 / RFU10013R5
Static pressure diagram

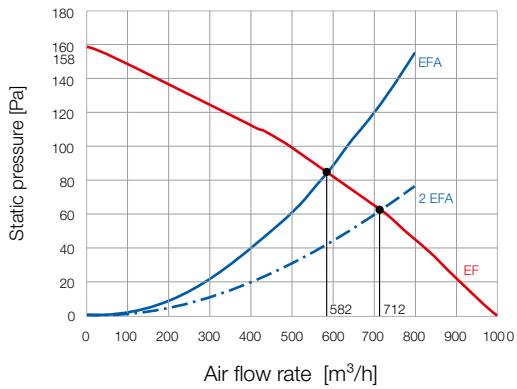

Performance

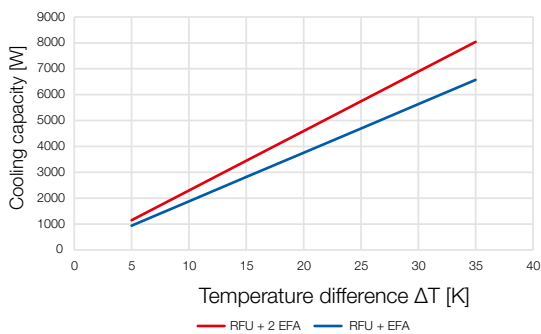

RFU10005R5 / RFU10015R5
Static pressure diagram

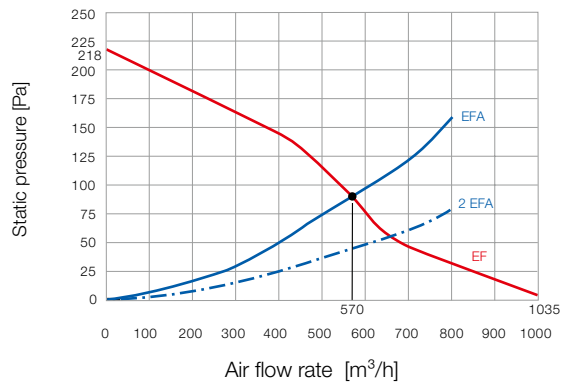

Performance

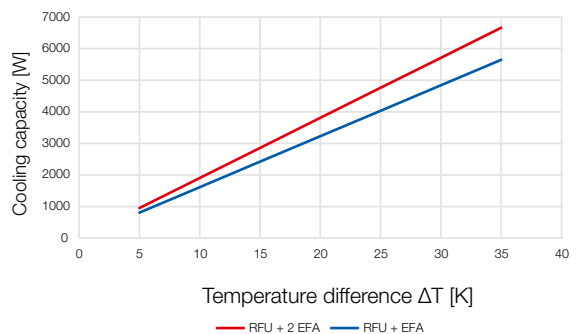

Архангельск (8182)63-90-72
Астана (7172)727-132
Астрахань (8512)99-46-04
Барнаул (3852)73-04-60
Белгород (4722)40-23-64
Брянск (4832)59-03-52
Владивосток (423)249-28-31
Волгоград (844)278-03-48
Вологда (8172)26-41-59
Воронеж (473)204-51-73
Екатеринбург (343)384-55-89
Иваново (4932)77-34-06

Ижевск (3412)26-03-58
Иркутск (395)279-98-46
Казань (843)206-01-48
Калининград (4012)72-03-81
Калуга (4842)92-23-67
Кемерово (3842)65-04-62
Киров (8332)68-02-04
Краснодар (861)203-40-90
Красноярск (391)204-63-61
Курск (4712)77-13-04
Липецк (4742)52-20-81

Киргизия (996)312-96-26-47

Магнитогорск (3519)55-03-13
Москва (495)268-04-70
Мурманск (8152)59-64-93
Набережные Челны (8552)20-53-41
Нижний Новгород (831)429-08-12
Новокузнецк (3843)20-46-81
Новосибирск (383)227-86-73
Омск (3812)21-46-40
Орел (4862)44-53-42
Оренбург (3532)37-68-04
Пенза (8412)22-31-16

Россия (495)268-04-70

Пермь (342)205-81-47
Ростов-на-Дону (863)308-18-15
Рязань (4912)46-61-64
Самара (846)206-03-16
Санкт-Петербург (812)309-46-40
Саратов (845)249-38-78
Севастополь (8692)22-31-93
Симферополь (3652)67-13-56
Смоленск (4812)29-41-54
Сочи (862)225-72-31
Ставрополь (8652)20-65-13

Казахстан (772)734-952-31

Сургут (3462)77-98-35
Тверь (4822)63-31-35
Томск (3822)98-41-53
Тула (4872)74-02-29
Тюмень (3452)66-21-18
Ульяновск (8422)24-23-59
Уфа (347)229-48-12
Хабаровск (4212)92-98-04
Челябинск (351)202-03-61
Череповец (8202)49-02-64
Ярославль (4852)69-52-93